

One & Two Bag Dust Extractions

These one and two bag extraction units are designed specially with the smaller workshops in mind.

With low operating costs, easy maintenance and proven reliability are just some of the great features of these one and two bag extractions units.



Bagging Units

The Single bag unit has been designed primarily to meet the needs of the smaller operator, with perhaps two or three machines and for use with an isolated machine where connection to the main extraction system is impractical.

This Unit can be fitted with a single or three phase motor.

All One bag units come with a simple direct on line push button starter, a Terylene needle felt top filter and five heavy duty polythene collections bags as standard.

The Two bag unit is a very economical solution where two or three woodworking machines need to be worked simultaneously. This can be achieved by either a two or three way multi-inlet or a small system of ductwork to connect the individual machines.

The duct inlet may be positioned on top or beneath the extraction unit.

* Please note!

These units are not suitable for extracting fine dust.

One Bag Dust Extraction Unit

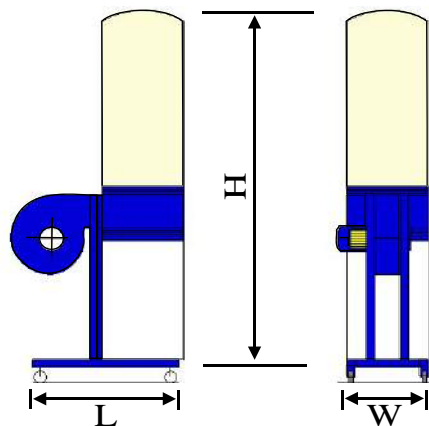

Model	Motor & Phase	Inlet Dia	CFM	Steel Impeller	Starter	L	W	H
FBM 1 - 2	2.0HP - 1ph	150	1100	3mm	D.O.L	1050	620	2500
FBM 1 - 2	2.0HP - 3ph	150	1100	3mm	D.O.L	1050	620	2500
FBM 1 - 3	3.0HP - 3ph	150	1200	3mm	D.O.L	1050	620	2500

Two Bag Dust Extraction Unit

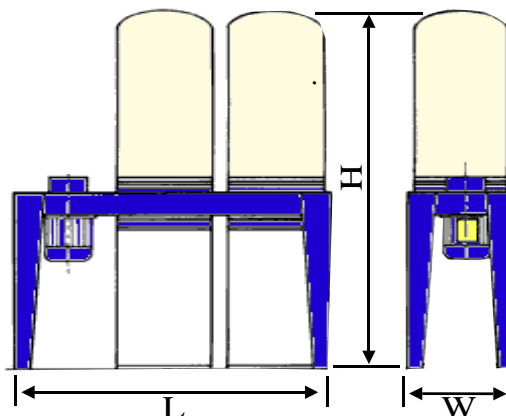

Model	Motor & Phase	Inlet Dia	CFM	Steel Impeller	Starter	L	W	H
FBM2 - 4	4.0HP - 3ph	200	1800	6mm	D.O.L	1650	585	2500
FBM2 - 5.5	5.5.0HP - 3ph	200	2000	6mm	D.O.L	1650	585	2500



BAGGING FILTERS



LARGE FILTERS



ANCILLERY



HEATERS



CHIPPERS