

## Technical data sheet

# ELEMAX

Portable extraction system



## APPLICATIONS



“ELE MAX” portable extraction fans were designed to resolve the problem of extracting exhaust gases in closed environments unequipped with wall or ceiling mounted extraction systems.

Once extracted, the gases are expelled to the external environment through your flexible hose.

The range offers various models and accessories designed for easy application over a wide range of use in motorcycle, car, truck and vehicle service centres.

## FEATURES

Trolley structure in powder-coated steel fitted on a support equipped with wheels.

Gas spring for assisted movement of the extraction chamber and positioning on the exhaust.

Simple extraction centrifugal fan coupled directly to the single phase electric motor (220/1/50) and electrical connection cable (5 m).

Coupling for extraction of exhaust gases (connection to flexible hose for extraction with a rubber nozzle and single or double exhaust upon request).

## CERTIFICATIONS



## TECHNICAL DATA

MOD.	FLOW RATE	POWER	VOLTAGE
	m <sup>3</sup> /h	KW	Volt/ph/Hz
ELEMAX	2000	1,1	230/1/50

## DIMENSIONS

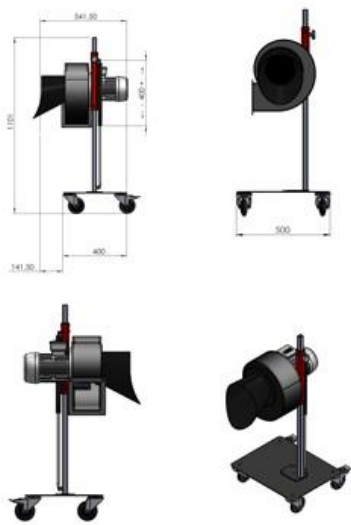

MOD.	A	B	C	D	E	G	H	Ø I
	mm	mm	mm	mm	mm	mm	mm	mm
ELEMAX	500	566	1020	420	400	344	242	125

**ACCESSORIES (Sold seperately)**

---

**“Y” COUPLERS and ”KIT AS CAR”**

---



Couplers in “Y” and “kit AS CAR” for extraction from vehicles with dual exhaust

---

**SINGLE COUPLER AND EXTRACTION KIT**

---



Single coupler and extraction kit for vehicles with single exhaust

---

**SINGLE COUPLER**

---



Single coupler for connection to positioners